

MIX 6W (NON TRIMLESS)

formula:

M	X	0	digit1	digit2	digit3	digit4	digit5
		6W IP54*	MODEL	BEAM ANGLE	COLOR TEMP LED	FOCUS COLOR	FRONT COLOR
			1: ROUND	N: 15°	1: HALOSPHERE 3000-1800K	1: MATT WHITE	6: TEXTURED BLACK
			2: ROUND FLEX	M: 36°	2: 2700K	2: MATT BLACK	7: TEXTURED WHITE
				W: 60°	3: 3000K	3: MATT GOLD	
			5: SQUARE		4: 4000K	4: BLACK CHROME	
			6: SQUARE FLEX				
EXAMPLE ARTNR MX01N217 = MIX 6W ROUND 15° 2700K IP54 MATT WHITE FOCUS TEXTURED WHITE FRONT							

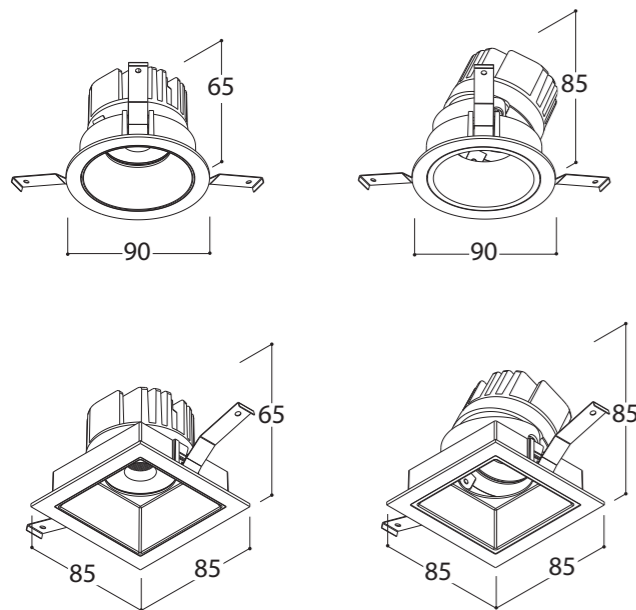

1 MAKE HOLE:
for round dia 76mm
for square = 76 x 76mm

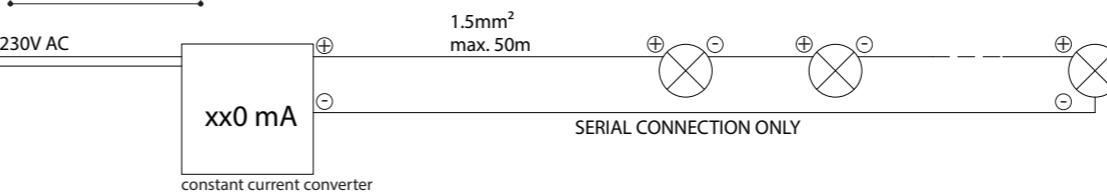
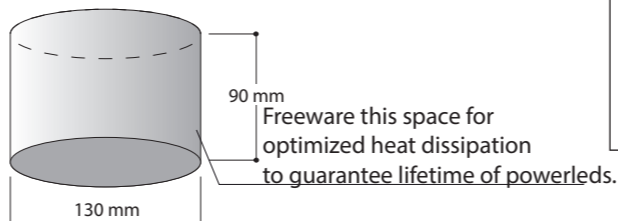
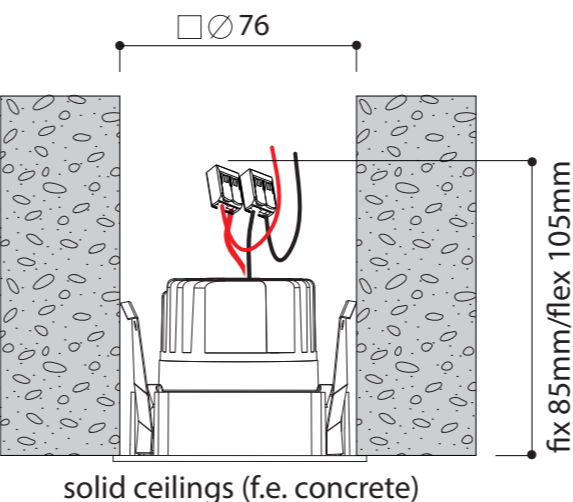
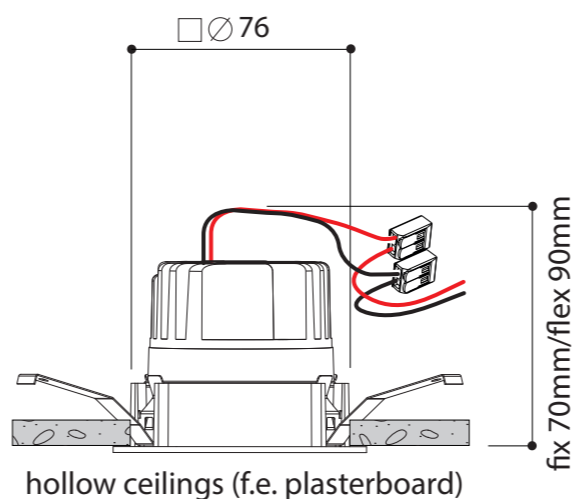

**INPUT CURRENT DIAGRAM:

COLORTEMP	180 mA				250mA				max. 350 mA			
	lm	P	lm/P	typ Vf	lm	P	lm/P	typ Vf	lm	P	lm/P	typ Vf
2700K	425	3,15	134,92	17,5	546	4,475	122,01	17,9	790	6,48	122,01	18,5
3000K	442	3,15	140,32	17,5	569	4,475	127,15	17,9	822	6,48	126,95	18,5
4000K	449	3,15	142,54	17,5	578	4,475	129,16	17,9	835	6,48	128,96	18,5
3000>1800K***	286	2,835	101	15,75	445	4,1	109	16,4	636	6	115	17

2 MAKE ELECTRICAL CONNECTION
(POWER SUPPLY IS SWITCHED OFF)

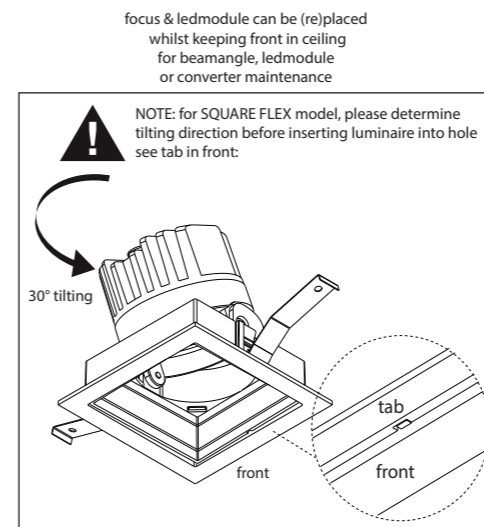
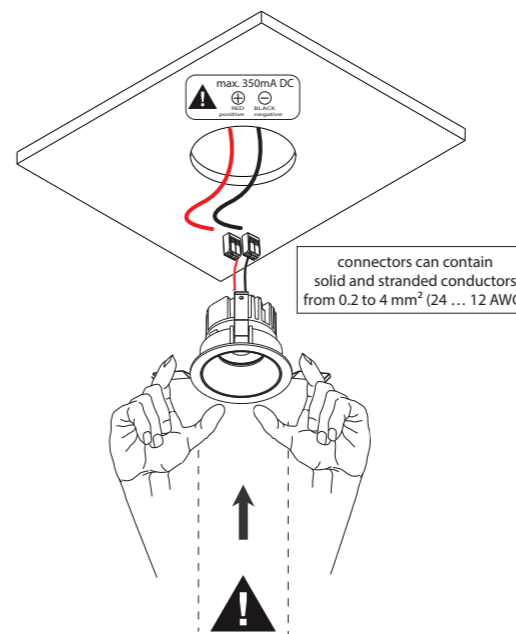

3 PUSH LUMINAIRE GENTLY INTO HOLE BY DEFORMING ALL LEAF SPRINGS UPWARDS BY HAND

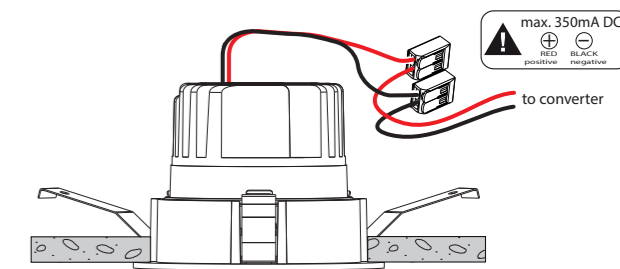

4 REMOVING THE FOCUS WITH THE 'MIX FOCUS REMOVAL TOOL'

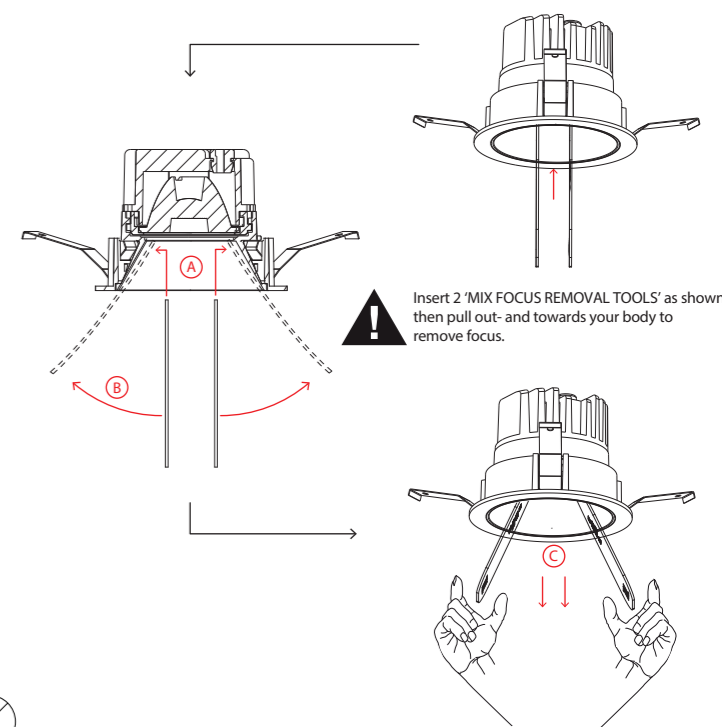

ALWAYS DISCONNECT MAINS POWER SUPPLY FROM CONVERTER BEFORE SWITCHING "ON" LED LUMINAIRES TO PREVENT HOT PLUGGING ISSUES

MIX monocolor

HALOSPHERE NXT MIX halosphere***

safe distance to object	- 0,1m -	- 0,1m -
lamptype	CITIZEN 790lm/822lm/835lm (@350mA) 2700K/3000K/4000K	BR.LUX 636lm (@350mA) 3000>1800K*
power	6W (@350mA)	6W (@350mA)
input current (Vf)**	Max. 350mA DC (Vf=18,5V)	Max. 350mA DC (Vf=17V)
symbol		
gear	Converter not incorporated	Converter not incorporated
ip/class	IP54* (ledmodule only for bathrooms)	IP54* (ledmodule only for bathrooms)
application	Interior - ceiling mounted	Interior - ceiling mounted
rotating	359° rotating (only for round flex models)	359° rotating (only for round flex models)
tilting	30° tilting (only for flex models)	30° tilting (only for flex models)
dimmability	PWM, CCR dimmable	CCR dimmable
weight	0,3	0,3
beamangle	15° / 36° / 60°	15° / 36° / 60°
CRI	90	90
SDCM	3	3

INSTALLATIE- EN ONDERHOUDSRICHTLIJNEN m.b.t. FABRIEKSGARANTIE.
1. DE VERBINDINGEN EN HET UITTESTEN VAN DEZE TOESTELLEN DIENEN ALTIJD TE GEBEUREN DOOR EEN ERKENDE ELECTRO-INSTALLATEUR.
2. DEZE VERLICHTINGSTOESTELLEN MOETEN GE-INSTALLEERD, VERBONDEN EN GETEST WORDEN VOLGENS DE NATIONAAL GELDENDE REGLEMENTEN OP DE ELECTRISCHE INSTALLATIES (BELGIE?, A.R.E.I., DUITSLAND: DIN VDE 0100 TEIL 559 A2, ...; DEZE OPSOMMING IS LOUWER INFORMATIEF)
3. DE TECHNISCHE BUSLUITER MOET GEZIEN WORDEN ALS ONDERDEEL VAN DE ALGEMENE VERKOOPVOORWAARDEN VAN TAL N.V.
4. DE ELECTRO-INSTALLATEUR IS VERANTWOORDELIJK VOOR HET GEBRUIKEN VAN VOORSCHAKELAPPARATUUR DIE VOLDOET AAN DE GELDENDE CE EN EMC NORMEN.
5. VERVANG DE LAMP (-EN) ALTIJD MET DE GROOTSTE ZORG, ZE IS (ZIJN) UITERST BREEKBAAR.
6. OPGEPAST: PLAATS NOOIT DE LAMP MET BLOTE HANDEN, GEBRUIK ALTIJD EEN DOEK!

INSTRUCTIONS D'INSTALLATION ET D'ENTRETIEN A RESPECTER VIS-A-VIS DE LA GARANTIE.
1. LE PLACEMENT, LE RACCORDEMENT ET L'ESSAI DE CET APPAREIL DOIVENT TOUJOURS ENTRE EFFECTUES PAR UN INSTALLATEUR ELECTRICIEN AGREE.
2. LES LUMINAIRES DOIVENT ETRE INSTALLEZ, BRANCHES ET TESTES SUIVANT LE REGLEMENT NATIONAL SUR LES INSTALLATIONS ELECTRIQUES EN VIGUEUR. (BELGIQUE, A.R.E.I., ALLEMAGNE: DIN VDE 0100 TEIL 559 A2, ...; CETTE ENUMERATION EST INDICATIVE)
3. CE MANUEL D'INSTALLATION TECHNIQUE REPRESENTE UNE PARTIE DES CONDITIONS GENERALES DE VENTE DE TAL N.V.
4. L'ELECTRO-INSTALLATEUR EST RESPONSABLE POUR L'USAGE DE BALLASTS, TRANSFO'S...CONFORMES AUX NORMES CE ET EMC EN VIGUEUR.
5. REMPLACEZ TOUJOURS L'AMPOULE (LES AMPOULES) AVEC PRUDENCE; ELLE(-S) EST (SONT) TRES FRAGILE (-S).
6. ATTENTION: NE JAMAIS REMPLACER L'AMPOULE AUX MAINS NUES, UTILISEZ TOUJOURS UN CHIFFON!

INSTALLATION AND MAINTENANCE INSTRUCTIONS IN VIEW OF THE MANUFACTURER'S GUARANTEE.
1. THE CONNECTION AND TESTING OF THE DEVICES SHOULD ALWAYS BE PERFORMED BY A RECOGNIZED ELECTRICIAN.
2. THESE LUMINAIRE DEVICES NEED TO BE INSTALLED, CONNECTED AND TESTED FOLLOWING THE OFFICIAL NATIONAL INSTRUCTION GUIDE FOR ELECTRICAL INSTALLATIONS (BELGIUM, A.R.E.I., GERMANY: DIN VDE 0100 TEIL 559 A2, ...; THIS ENUMERATION IS JUST AN INDICATION)
3. THIS TECHNICAL ENCLOSURE NEEDS TO BE ADDED TO THE GENERAL SALES CONDITIONS OF THE TAL N.V.
4. THE ELECTRO TECHNICIAN IS RESPONSIBLE TO USE BALLASTS, TRANSFORMERS...WHICH MEET THE VALID CE AND EMC RULES.
5. ALWAYS REPLACE THE LAMP (-S) WITH UTMOST CAUTION, THE LAMP (-S) IS (ARE) VERY FRAGILE.
6. ATTENTION: NEVER REPLACE THE LAMP WITH BARE HANDS, ALWAYS USE A CLOTH!

MONTAGE- UN UNTERHALT INSTRUCTIONS ZU BEACHTEN MIT BEZUG AUF DER GARANTIE.
1. DIE MONTAGE, DER ANSCHLUSS UND DAS AUSTESTEN DER LEUCHTEN SOLL IMMER VON EINEM ZUSTAENDIGEN ELECTRO-INSTALLATEUR AUSGEFUHRT WERDEN.
2. DIESE LEUCHTEN MUSSEN INSTALLIERT, ANGESCHLOSSEN UND GETESTET WERDEN NACH DER ALLGEMEINEN NATIONALEN REGLEMENTATION UBER DIE ELEKTRISCHE INSTALLATIONEN (BELGIEN, A.R.E.I., DEUTSCHLAND: DIN VDE 0100 TEIL 559 A2, ...; DIESE AUFSTELLUNG GESCHICHT DURCH EXEMPLATIVEN TITEL UND KANN NICHT ALS LIMITATIV ODER EXHAUTIV BETRACHTET WERDEN).
3. DIESE TECHNISCHE GEBRAUCHSANWEISUNG GEHORT ZU DEN ALLGEMEINEN VERKAUFSDINGUNGEN VON TAL N.V.
4. DER ELEKTRO-INSTALLATEUR IST VERANTWORTLICH FUR DAS VERWENDEN VON CE UND EMC GEPRUFTE VORSCHALTGERAETE.
5. DIE LAMPE(-N) SOLL(-EN) IMMER SERH VORSICHTIG ERSAETZT WERDEN.
6. VORSICHT: MAN DARF NIE DIE LAMPE MIT DEN NACKTEN HAENDEN BERUHREN, MAN SOLL IMMER EINEN TUCH BENUTZEN!